

MULTIPLE CHOICE SOLUTIONS--E&M

TEST IV

1.) In a 10 second period, a -2 coulomb charge is made to move with a constant velocity from the top to the bottom of the electrical potential field shown.

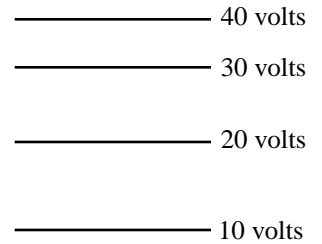

a.) The electric field direction will be downward and the power provided by the field will equal +6 watts, where the positive sign signifies the fact that the charge's potential energy has increased. [An electric field's direction is defined as the direction a positive test charge will accelerate if put in the field. As free positive charges always migrate from higher electrical potential to lower electrical potential, the electric field in this case must be downward and the first part of this response is true. As for the second part, the power provided to the system will equal the work per unit time provided by the field. We know that the work done by an electric field on a charge moving from one point to another in the field will be  $W = -q\Delta V$ , where  $\Delta V$  is the voltage difference between the points in question and the sign of the charge must be included (the expression is actually for the work on a positive charge--if we want to alter it for a negative charge, we need a negative sign from somewhere and might as well take it from the charge). For our situation,

$W = -q\Delta V = -(-2\text{coul})(10\text{volts} - 40\text{volts}) = -60\text{joules}$  (this makes sense as this negative charge is moving from higher to lower electrical potential--i.e., opposite the direction it would freely accelerate--hence, the work done to it by the field must be negative). Power is defined as the work done per unit time. For this case, that will be  $P = W/t = (-60\text{joules})/(10\text{seconds}) = -6$  watts. The negative sign signifies the fact that the field is removing energy from the system, leaving the charge with less potential energy than it began with. This response is false.]

b.) The electric field direction will be upward and the power provided by the field will equal -6 watts, where the negative sign signifies the fact that the charge's potential energy has decreased. [From above, this response is false.]

c.) The electric field direction will be downward and the power provided by the field will equal -6 watts, where the negative sign signifies the fact that the charge's potential energy has decreased. [This is the one.]

d.) None of the above. [Nope.]

2.) For the circuit shown:

a.)  $16i_5 - 15i_4 + 20 = 0$ . [The loops used for all of the equations written for this question are highlighted in the auxiliary sketch. Summing the voltage changes around LOOP a yields  $16i_5 - 15i_4 - 20 = 0$ . This response is false.]

b.)  $-15i_4 - 18i_6 + 9i_2 = 15$ . [Examining LOOP b, this response is true.]

c.)  $60 + 37i_7 + 10i_1 + 16i_5 = 0$ . [From LOOP c, this would be right if the  $i_5$

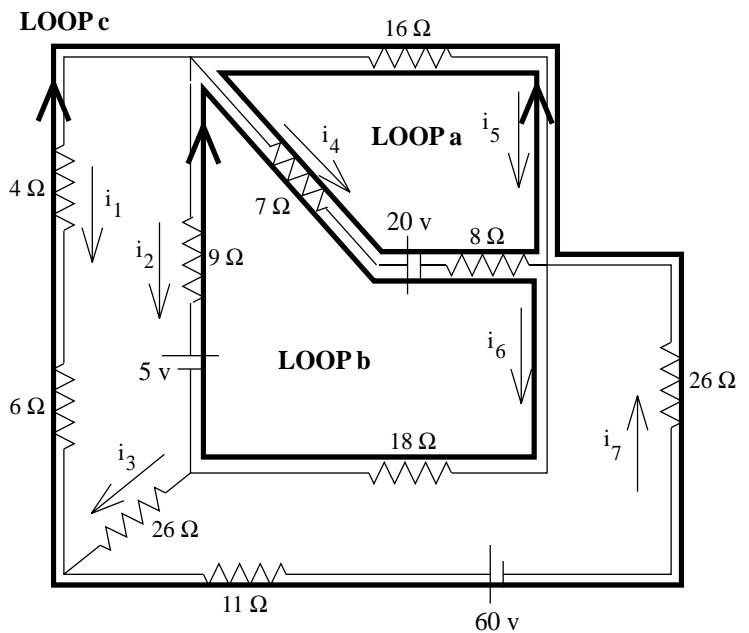

term had been negative. It wasn't, so this response is false.]

- d.) Both b and c. [Nope.]
- e.) None of the above. [Nope.]

3.) What is the magnitude of the magnetic field at the center of the two connected arcs?

a.) There is not enough information to complete this problem. [This is a Biot Savart problem. A section of current of length  $dl$  is defined on the accompanying sketch. The vector  $r$  is also defined on that sketch. Note that the angle between  $r$  and  $dl$  is  $90^\circ$  and that the sine of that angle is 1. Using Biot Savart on the section whose radius is  $c$ , we get:

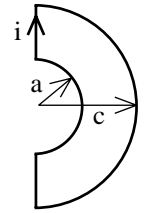

$$\begin{aligned}
 B &= \int dB = \int \frac{\mu_0 i}{4\pi} \frac{dl \sin 90^\circ}{r^2} \\
 &= \frac{\mu_0 i}{4\pi c^2} \int dl \\
 &= \frac{\mu_0 i}{4\pi c^2} \left( \frac{2\pi c}{2} \right) \\
 &= \frac{\mu_0 i}{4c}
 \end{aligned}$$

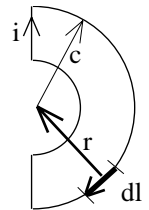

The direction of this field will be into the page at the center point (right-thumb rule). A similar expression governs the current in the section of wire whose radius is  $a$ , but the direction of its magnetic field will be out of the page. Finally, there will be no magnetic field component due to the bits of current that are on line with the center point (i.e., the straight line segments that align themselves with the center--in both cases, the sine of the angle between  $r$  and  $dl$  will be zero as the angles will be either  $0^\circ$  or  $180^\circ$ ). Summing the fields at the center point yields  $-\frac{\mu_0 i}{4c} + \frac{\mu_0 i}{4a}$ . This is the net magnetic field at that point. This response is false.]

- b.)  $-\frac{\mu_0 i}{4c} + \frac{\mu_0 i}{4a}$ . [This is the one.]
- c.)  $-\frac{\mu_0 i}{4c} - \frac{\mu_0 i}{4a}$ . [Nope.]
- d.) None of the above. [Nope.]

4.) The charge ratio between capacitors  $C_1$  and  $C_2$  is:

a.) 1:2. [The voltage across the two capacitors will be the same (they are in parallel). As such, we can write  $V = Q_1/C_1 = Q_2/C_2$ . This implies that  $Q_1/(2 \times 10^{-2} \text{ f}) = Q_2/(10^{-2} \text{ f})$ , or  $Q_1 = 2 Q_2$ . As there is twice the charge on  $Q_1$  as on  $Q_2$ , the ratio we are looking for is 2:1, and this response is false.]

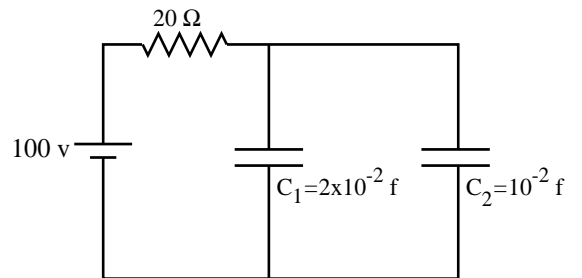

- b.) 2:1. [This is the one.]
- c.) 2:4. [Nope.]
- d.) None of the above. [Nope.]

5.) The induced voltage across a .6 mH inductor is shown in the graph to the right. The rate of change of the current at  $t = .5$  seconds will be:

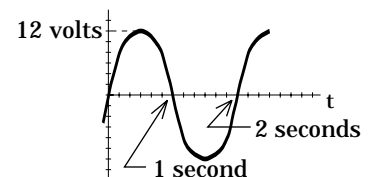

a.) Zero. [At  $t = .5$  seconds, the induced voltage graph is at its positive maximum. As  $\varepsilon = -L \frac{di}{dt}$ , a 12 volt induced EMF means that the slope of the current versus time graph must itself be a maximum at  $t = .5$  seconds. As such, this response is false.]

b.)  $-2 \times 10^4$  amps/second. [Knowing the induced EMF at  $t = .5$  seconds, we can use  $\varepsilon = -L \frac{di}{dt}$  to write (12 volts) =  $-(.6 \times 10^{-3} \text{ henrys})(di/dt)$ , or  $di/dt = -20 \times 10^3$  amps. This response is true.]

c.)  $7.2 \times 10^{-4}$  amps/second. [Nope.]

d.) None of the above. [Nope.]

6.) A spherical conducting shell of radius  $b$  bounds a dielectric-filled region (dielectric constant  $\kappa_d$ ) centered on a second smaller conducting shell of radius  $a$  (see sketch). The capacitance of the system is:

a.)  $[4\pi \kappa_d \varepsilon_0 (b-a)]/(ab)$ . [About the only way to do this problem is to do the problem, so here we go. The defining equation for a problem like this is  $C = q/V_c$ , where  $q$  is the charge on one plate of the capacitor and  $V_c$  is the magnitude of the voltage difference between the plates. To determine the voltage difference, we need to use the relationship

$-\Delta V = \int \mathbf{E} \cdot d\mathbf{l}$ , where  $\mathbf{E}$  is the electric field vector between the plates (note that  $-\Delta V = \int \mathbf{E} \cdot d\mathbf{l}$  really determines the amount of work per unit charge done as a charge goes from one plate to the other). If we assume there is charge  $+q$  on the inner plate and  $-q$  on the outer plate, the electric field between the plates will be outward and we will have the classical capacitor setup . . . two oppositely charged plates in the vicinity of one another. All we need to proceed is the magnitude of the electric field vector between the plates. To determine that, we have to use Gauss's Law (assuming we don't already know the magnitude of  $\mathbf{E}$ ). To start, define a Gaussian sphere a distance  $r$  units from the capacitor's center, where  $a < r < b$ . Remembering that by including  $\kappa_d$  in our Gauss's Law expression, we can ignore the induced charge on the dielectric's surface and treat  $q_{\text{enclosed}}$  solely as the free charge on the plate, Gauss's Law yields:

$$\begin{aligned} \kappa_d \int \mathbf{E} \cdot d\mathbf{S} &= \frac{q_{\text{enclosed}}}{\varepsilon_0} \\ \Rightarrow \kappa_d \int E(dS) \cos 0^\circ &= \frac{+q}{\varepsilon_0} \\ \Rightarrow E \int (dS) &= \frac{q}{\kappa_d \varepsilon_0} \\ \Rightarrow E(4\pi r^2) &= \frac{q}{\kappa_d \varepsilon_0} \\ \Rightarrow E &= \frac{q}{(4\pi r^2) \kappa_d \varepsilon_0} \end{aligned}$$

With an expression for the magnitude of the E-field, we can now do the work per unit charge calculation to determine the voltage difference between the plates. Moving from the inner sphere at higher voltage to the outer sphere at lower voltage (i.e., moving in the direction of the electric field), we can write:

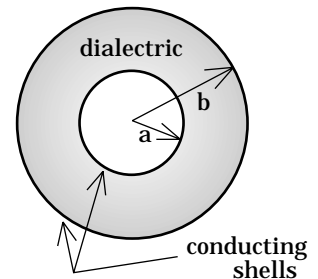

$$\begin{aligned}
\Delta V &= -\int_{r=a}^b \mathbf{E} \cdot d\mathbf{r} \\
\Rightarrow (V_{lo} - V_{hi}) &= -\int_{r=a}^b \left( \frac{q}{4\pi\kappa_d\epsilon_0 r^2} \mathbf{r} \right) \cdot (d\mathbf{r}) \\
&= \frac{-q}{4\pi\kappa_d\epsilon_0} \int_{r=a}^b \left( \frac{1}{r^2} \right) dr \\
&= \frac{-q}{4\pi\kappa_d\epsilon_0} \left( -\frac{1}{r} \right)_{r=a}^b \\
&= \frac{q}{4\pi\kappa_d\epsilon_0} \left( \frac{1}{b} - \frac{1}{a} \right) \\
&= \frac{-q}{4\pi\kappa_d\epsilon_0} \left( \frac{1}{a} - \frac{1}{b} \right).
\end{aligned}$$

The voltage  $V_c$  across the capacitor is a positive value equal to  $(V_{hi} - V_{lo})$ , so the expression we have derived above (i.e.,  $V_{lo} - V_{hi}$ ) is minus the value we need. In other words,

$$V_c = \frac{q}{4\pi\kappa_d\epsilon_0} \left( \frac{1}{a} - \frac{1}{b} \right).$$

Putting this together with the relationship  $C = q/V_c$ , the  $q$  terms cancel

and we end up with  $C = \frac{4\pi\kappa_d\epsilon_0}{\left( \frac{1}{a} - \frac{1}{b} \right)} = 4\pi\kappa_d\epsilon_0 \frac{ab}{(b-a)}$ . (Note that that last expression was

determined by finding the common denominator between the two fractions and simplifying.) In any case, this response is false.]

- b.)  $(4\pi\kappa_d\epsilon_0 ab)/(b-a)$ . [This is the one.]
- c.)  $qab/[(4\pi\kappa_d\epsilon_0)(b-a)]$ . [Nope.]
- d.) None of the above. [Nope.]

7.) A 10 amp fuse is placed in series with an RL circuit in which the AC voltage amplitude is 1500 volts, the net resistance is 140  $\Omega$ , and the inductance is 20 mH. Approximately what is the lowest frequency the power supply can operate at without blowing the fuse?

a.)  $1.10 \times 10^4$  Hz. [On the surface, this may seem like an odd question to ask (that is, why not ask for the largest frequency the system can handle?). The wording is a consequence of the fact that at low frequency, the inductive reactance is low and the current high. It isn't until you get into higher frequencies that you find a diminishing of current. As such, below a certain frequency the current will be too big. As for the problem: Under normal circumstances, Ohm's Law should be used with RMS values. In this case, though, the .707 factor will simply cancel out. As such, I will use amplitude values instead (this is actually useful here as the current you don't want to exceed is not 10 amps RMS but 10 amps maximum). Using the appropriate expression for the impedance of an RL circuit, we can write Ohm's Law as  $V_{max} = i_{max}Z = i_{max}\sqrt{R_{net}^2 + (2\pi\nu L)^2}$ . Putting in the appropriate values, we get 1500 volts = [10 amps][ $[140 \Omega]^2 + [2\pi\nu(2 \times 10^{-3} \text{ henrys})]^2$ ]<sup>1/2</sup>. Solving yields  $\nu = 4.285 \times 10^3$  hertz. This response is false.]

- b.)  $2.35 \times 10^4$  Hz. [Nope.]
- c.)  $4.29 \times 10^3$  Hz. [This is the one.]

d.) None of the above. [Nope.]

8.) At a distance of  $1R$  from a field-producing point charge, the coulomb force on a test charge is  $1F$ . What is the slope of the force vs. position graph for that charge as evaluated at a distance  $3R$ ?

- a.)  $-FR/3$ . [The Coulomb force function is  $\frac{1}{4\pi\epsilon_0} \frac{q_1q_2}{r^2}$ . The derivative of that force function with respect to  $r$  is  $\frac{q_1q_2}{4\pi\epsilon_0} \left( \frac{d(r^{-2})}{dr} \right) = \frac{q_1q_2}{4\pi\epsilon_0} (-2r^{-3}) = -\frac{2q_1q_2}{4\pi\epsilon_0 r^3}$ . Evaluating this at the position  $r = 3R$ , we get  $-\frac{2q_1q_2}{4\pi\epsilon_0 r^3} = -\frac{2q_1q_2}{4\pi\epsilon_0 (3R)^3} = -\frac{q_1q_2}{4\pi\epsilon_0 R^2} \frac{2}{27R} = -F \frac{2}{27R}$ . This response is false.]
- b.)  $-F/3R$ . [Nope.]
- c.)  $-F/9R$ . [Nope.]
- d.)  $-2F/27R$ . [This is the one.]
- e.) None of the above. [Nope.]

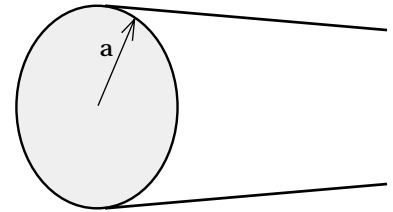

9.) A solid cylinder of radius  $a$  has a volume charge density shot through it of  $-k_2/r$ , where  $k_2$  is a constant. The electric field function outside of  $a$  is:

- a.)  $\frac{-k_2 a}{\epsilon_0 r}$ . [Defining a Gaussian cylinder of length  $L$  and radius  $r > a$ , we need to determine the total charge inside the charged area. Using a cylindrical shell of radius  $c$ , thickness  $dc$ , circumference  $2\pi c$ , and differential volume  $dV = (2\pi c dc)L$ , Gauss's Law yields:

$$\begin{aligned} \int \mathbf{E} \cdot d\mathbf{S} &= \frac{q_{\text{enclosed}}}{\epsilon_0} \\ \Rightarrow E(2\pi r L) &= \frac{\int \rho dV}{\epsilon_0} \\ \Rightarrow E &= \frac{\int_{c=0}^a (-k_2/c)(2\pi c L) dc}{(2\pi r L)\epsilon_0} \\ \Rightarrow E &= -\frac{k_2 \int_{c=0}^a dc}{r\epsilon_0} \\ \Rightarrow E &= -\frac{k_2 a}{\epsilon_0 r} \end{aligned}$$

It looks like this is the one.]

- b.)  $\frac{-k_2}{\epsilon_0 r} (r - a)$ . [Nope.]
- c.)  $\frac{-k_2}{2\epsilon_0 r^2} (r^2 - a^2)$ . [Nope.]
- d.) None of the above. [Nope.]

10.) A .5 kg mass has a 10 coulomb charge on it. It is placed at  $x = 3$  meters in an electric field equal to  $(kx)i$ , where  $k = 1 \text{ nt}/(\text{coulomb}\cdot\text{meter})$ . The voltage at  $x = 3$  meters is  $-4.5$  volts. Released from rest, the mass is allowed to accelerate freely to a point whose voltage is  $-18$  volts. At that point:

a.) The mass's coordinate is  $x = 13.5$  meters. [We know that the relationship between a varying electric field and its associate electrical potential field is  $V(x_2) - V(x_1) = -\int_{x_1}^{x_2} \mathbf{E} \cdot d\mathbf{r}$ .

Setting  $k = 1$  and using that relationship, we get:

$$(-18\text{volts}) - (-4.5\text{volts}) = -\int_{x=3}^x (xi) \bullet (dxi) = -\left[ \frac{x^2}{2} \right]_{x=3}^x = -\left( \frac{x^2}{2} - \frac{(3)^2}{2} \right), \text{ or } x = 6 \text{ meters. This}$$

response is false.]

- b.) The mass's coordinate is  $x = 12$  meters. [Nope.]
- c.) The mass's coordinate is  $x = 6$  meters. [This is the one.]
- d.) None of the above. [Nope.]

11.) In the circuit below, each of the resistors characterized by  $R$  is the same size. As far as equivalent resistance goes, which of the combinations comes closest to a single resistor  $R$ ?

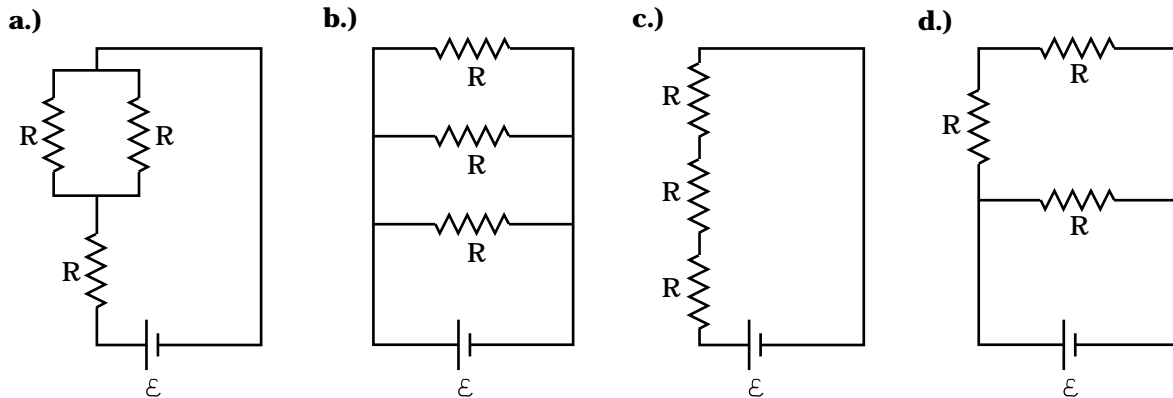

a.) Circuit a. [We know that the equivalent resistance of the series combination (Circuit c) will be the largest, and we know that the equivalent resistance of the parallel combination (Circuit b) will be the smallest. We can eliminate them. As for the other two, the equivalent resistance for Circuit a is  $R_{eq} = R + \frac{1}{1/R + 1/R} = R + \frac{1}{2/R} = \frac{3}{2}R$ . The equivalent resistance of Circuit d is  $\frac{1}{R_{eq}} = \frac{1}{(R+R)} + \frac{1}{R} = \frac{1}{2R} + \frac{2}{2R} = \frac{3}{2R}$ , or  $R_{eq} = (2/3)R$ . Circuit d's equivalent resistance is closer to  $R$ , so Circuit d is the one and this response is false.]

- b.) Circuit b. [Nope.]
- c.) Circuit c. [Nope.]
- d.) Circuit d. [This is the one.]

12.) A graph of the voltage across an AC power supply is shown. The voltage can be characterized as:

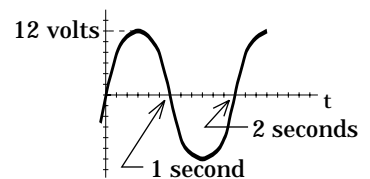

a.)  $12 \sin(\pi t)$  volts. [The general expression for an AC power supply is  $V(t) = V_o \sin(\omega t + \phi) = V_o \sin((2\pi\nu)t + \phi)$ . In this case, there is no phase shift, so phi is zero. The amplitude of the source is 12 volts. Looking at the graph, the period of oscillation is 2 seconds per cycle, so the frequency is .5 cycles per second. The angular frequency is equal to  $2\pi\nu = 2\pi(.5 \text{ Hz}) = \pi$  radians per second. Putting it all together, we get  $12 \sin(2\pi(.5 \text{ Hz})t + 0) = 12 \sin(\pi t)$  volts. This response is true.]

- b.)  $12 \sin(2t)$  volts. [Nope.]  
 c.)  $12 \sin(2\pi t)$  volts. [Nope.]  
 d.) None of the above. [Nope.]

13.) A positively charged conducting rod is brought in close to an uncharged conducting ball as shown in the "before" sketch. The rod is then rotated to the position shown in the "after" sketch. Point A is very, very close to the ball.

a.) The net electric field at Point A will have the same magnitude in the two scenarios, and the direction of the net electric field at Point A will also be the same in both scenarios. [The rod is a conductor. That means that positive charge will accumulate at the rod's end. In both cases, valence electrons in the uncharged sphere will migrate to the rod-side of the sphere. For reference, assume we place an axis through the rod that additionally cuts through the sphere (see sketch). In the first situation, due to symmetry, the induced charge will be uniformly distributed about that axis (again, see sketch). That means that there will be as much negative charge above the axis as below, and the direction of the net electric field will be toward the sphere (i.e., to the right) along the axis. When the rod is turned, the induced negative charge will shift upwards toward the maximum charge density on the rod (i.e., upward toward the rod's pointed end--again, see sketch). In that case, the high charge density at the end of the rod will be farther away, which means that the negative charge migration in the sphere will not be as great as it was in the first case when the rod's point was so much closer. But even if the amount of polarized negative charge in the sphere was the same as in the first situation, the position of maximum charge density on the sphere will be above the axis (see sketch), leaving Point A with less charge in its immediate vicinity and registering a smaller E-field.

Bottom line: the magnitude of the resulting electric field at A will be LESS in the second situation. As for the direction, we are assuming that A is very, very close to the sphere's surface. The electrical potential (the voltage) of the sphere must be the same everywhere on the sphere because it is a conductor (this doesn't contradict our situation--the electric field intensity will vary from point to point just outside the sphere's surface because an electric field is related to the spatial rate of change of the electrical potential at a particular point, not the magnitude of the electrical potential at that point). The only way the sphere can have the same electrical potential everywhere on its surface is if the equipotential lines just outside the boundary of the surface are very, very close to being concentric. That means that the electric field very, very close to the surface must be perpendicular to the surface and inward (inward--to the right in our sketch--because that is the direction a positive test charge would accelerate if

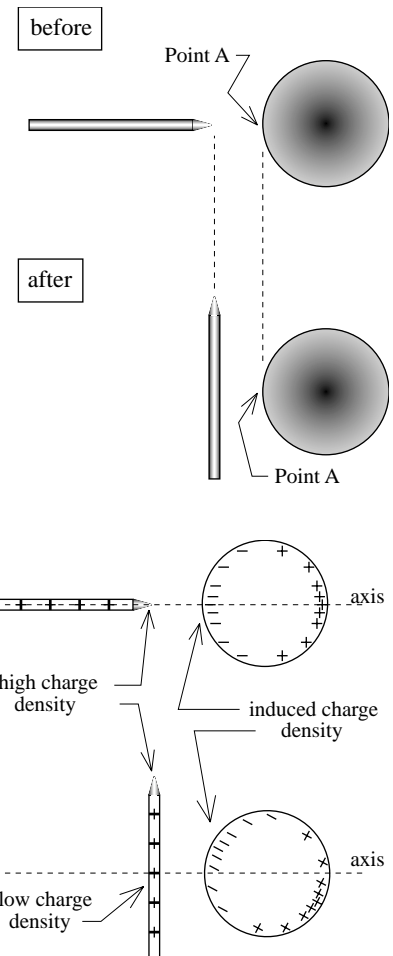

put in the field at that point). The temptation is to assume that because there is more negative charge on the sphere above the axis than below the axis, the negative charge above the axis will produce a disproportionate field effectively creating an additional electric field component upward. This is not the case. The positive charge on the rod will produce an additional electric field component that will be downward, and the two y components will add to zero. As such, the net electric field will be to the right along the axis (i.e., perpendicularly inward toward the sphere's surface) as surmised above. In any case, this response is false.]

b.) The net electric field at Point A will have the same magnitude in the two scenarios, but the direction of the net electric field at Point A in the after situation will have a component toward the bottom of the page. [Nope.]

c.) The net electric field at Point A will not have the same magnitude in the two scenarios, and the direction of the net electric field at Point A in the after situation will have a component toward the bottom of the page. [Nope.]

d.) The net electric field at Point A will not have the same magnitude in the two scenarios, and the direction of the net electric field at Point A in the after situation will have a component toward the top of the page. [Nope.]

e.) None of the above. [This is the one.]

14.) Consider the circuit shown. If four more 10 volt batteries were added in parallel to the power supplies already there:

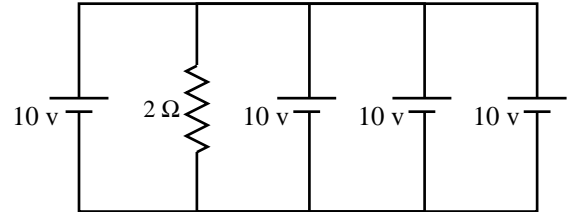

already there:

a.) Both the power and current provided by each battery will remain the same. [We really don't have a handy-dandy formula that relates the current behavior through a combination of voltage sources stacked in parallel, so all you can do in a situation like this is use your head. Effectively, what we know is that a net 10 volts across a  $2\ \Omega$  resistor will draw 5 amps of current through the resistor ( $V = iR$ ). From symmetry, it is not outrageous to assume that each power source supplies the same amount of current and power ( $P = iV$ ). In other words, if you add the power supplies to the parallel combination, the amount of current each power supply will have to provide will go down, and so will the power requirements for each supply. This response is false.]

b.) Both the power and current provided by each battery will decrease by 1/2. [The current and power will decrease, but will it decrease by a factor of 1/2? If you double the number of power sources, you halve the required current per source. As the power supplied by a power source is proportional to the current drawn from the source ( $P = iV$ ), halving the current requirement halves the power requirement and this response is true.]

c.) Both the power and current provided by each battery will decrease by 1/4. [Nope.]

d.) None of the above. [Nope.]

15.) Four equal, uncharged series capacitors are connected in series with a switch and a fixed-voltage power source (call this circuit 1). When the switch connecting the power supply to the capacitors is closed, Q's worth of charge is drawn from the power supply during the time it takes for the capacitors to fully charge. A nearly identical second circuit (call this circuit 2) has five uncharged series capacitors instead of four. The power supply is exactly the same, and when its switch is closed the circuit's capacitors are given enough time to charge fully.

a.) The net capacitance of circuit 2 will be greater than that of circuit 1. Also, the total charge drawn from the power supply in circuit 2 will be greater than that drawn in circuit 1.

[Adding a capacitor to a series combination decreases the equivalent capacitance (this is like adding a resistor to a parallel combination of resistors). As such, this response is false.]

b.) The net capacitance of circuit 2 will be greater than that of circuit 1. Also, the total charge drawn from the power supply in circuit 2 will be less than that drawn in circuit 1. [From above, this response is false.]

c.) The net capacitance of circuit 2 will be less than that of circuit 1. Also, the total charge drawn from the power supply in circuit 2 will be less than that of circuit 1. [From above, the first part of this response is true. As for the second part: Once the four capacitors of circuit 1 are charged, the voltage across each will be  $V/4$ , where  $V$  is the voltage across the power supply. As  $Q_1 = C_1 V_1$ , the charge on each capacitor will be  $Q_1 = C(V/4)$ . Adding a fifth capacitor means that the voltage across each charged capacitor becomes  $V/5$  and the charge on each capacitor becomes  $C(V/5)$ . In other words, the charge on each capacitor will decrease and this response is true.]

d.) None of the above. [Nope.]

16.) A coil is placed in a changing magnetic field. A graph of the induced EMF in the coil is shown on each of the grids below. Which graph depicts the appropriate B-field function, given the EMF function?

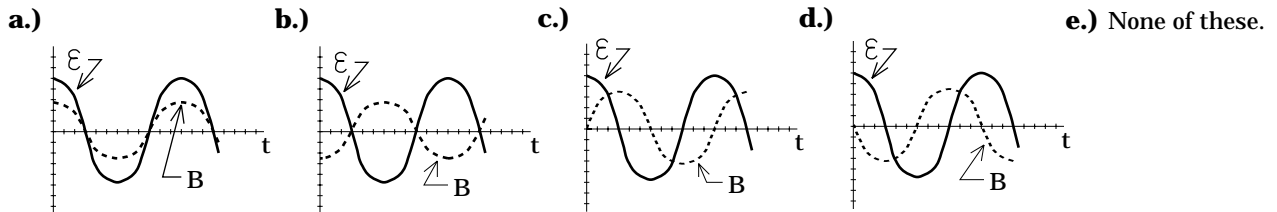

[Commentary: For a constant coil area and angle, the relationship between the changing magnetic field through a coil (hence, the changing magnetic flux through the coil) and the EMF that is setup as a consequence of that change is  $\varepsilon = -(NA \cos\theta) \frac{dB}{dt}$ . Technically,

determining the magnitude of  $B$ , given the EMF function, requires you to determine the area under the EMF vs. Time graph to determine how  $B$  changes from point to point in time. A considerably easier way to do this problem is to look at the proposed B-field function, take the slope of each, then see if minus that result matches the EMF graph. Following that line: In graph a, the slope of the B-field function at  $t = 0$  is zero. The EMF function on that graph, as evaluated at  $t = 0$ , shows itself to be a maximum. This doesn't match, so this response is false. A similar problem exists for graph b. Graph c shows a B-field slope at  $t = 0$  to be maximum and positive. The EMF function that goes with such a B-field should be maximum and negative, which isn't what we have, so this graph won't do. Graph d does seem to match nicely. That is the appropriate response.]

17.) Charge  $Q$  is uniformly distributed through a solid sphere. The voltage at Point A is known to be 10 volts. Point B is twice as far from the sphere's center as is Point A.

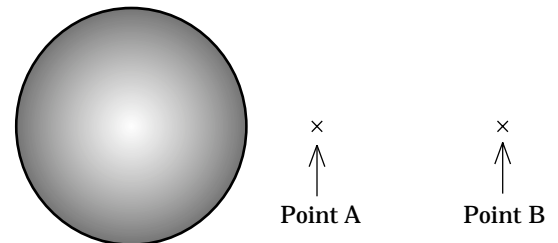

- a.) The voltage at Point B is 20 volts. [Outside the sphere, the electrical potential function will be that of a point charge, or  $V = \frac{1}{4\pi\epsilon_0} \frac{Q}{r}$ , where Q is the field-producing charge and r is the distance from that charge's CENTER. This may seem weird, but by doubling the distance from the center, the voltage should change by a factor of 1/2 even though you aren't twice the distance from the sphere's outer surface. In short, the new voltage should be 5 volts, and this response is false.]
- b.) The voltage at Point B is 10 volts. [Nope.]
- c.) The voltage at Point B is 5 volts. [This is the one.]
- d.) The voltage at Point B is 2.5 volts. [Nope.]
- e.) None of the above. [Nope.]

18.) A spherical shell has an inside radius of a and outside radius of b. The charge density within the shell is k/r, where k is a constant with appropriate units.

a.) The shell is a conductor whose charge density decreases as r increases, and whose electric field inside the shell increases as r increases. [At the very least, it should be obvious that a 1/r charge density is going to decrease as r increases, so the first part of this is true. Unfortunately, this can't be a conductor because there is charge shot through the structure. As such, this response is false.]

b.) The shell is a conductor whose charge density decreases as r increases, and whose electric field inside the shell decreases as r increases. [This shell can't be a conductor. This response is false.]

c.) The shell is an insulator whose charge density decreases as r increases, and whose electric field inside the shell increases as r increases. [This is an insulator and the charge density does decrease as r increases. The first two parts of this response are true. Looking at the last: As r increases, the volume increases as  $r^3$ . That means that the volume increases with r faster than the charge density decreases. Does this mean that the electric field intensity should decrease with an increasing r? Not necessarily. We need to use Gauss's Law with a Gaussian surface located between a and b to find out. Doing so, we write:

$$\int \mathbf{E} \cdot d\mathbf{S} = \frac{q_{\text{enclosed}}}{\epsilon_0}$$

$$\Rightarrow \int E(dS) \cos 0^\circ = \frac{\int_a^r \rho dV}{\epsilon_0}$$

$$\Rightarrow E \int (dS) = \frac{\int_a^r \left(\frac{k}{r}\right) (4\pi r^2 dr)}{\epsilon_0}$$

$$\Rightarrow E(4\pi r^2) = \frac{4\pi k \int_a^r r dr}{\epsilon_0}$$

$$\Rightarrow E = \frac{k}{\epsilon_0 r^2} \left( \frac{r^2}{2} - \frac{a^2}{2} \right)$$

$$\Rightarrow E = \frac{k}{\epsilon_0} \left( \frac{1}{2} - \frac{a^2}{2r^2} \right)$$

Evaluating this at  $r = a$  yields  $E = 0$ . Evaluating this at  $r = (3a)/2$  yields a positive electric field. Evidently, the electric field increases with  $r$ , and this response is true.]

d.) The shell is an insulator whose charge density decreases as  $r$  increases, and whose electric field inside the shell decreases as  $r$  increases. [Nope.]

e.) None of the above. [Nope.]

19.) The inductance of the inductor in the circuit shown is 10 mH and its resistor-like resistance is  $100 \Omega$ . The load resistor is  $R = 1000 \Omega$ . The frequency of the source is 20,000 cycles/second. The impedance of the circuit is:

a.)  $1107 \Omega$ . [In its most general form, the impedance expression is  $Z = \sqrt{R_{net}^2 + (X_L - X_C)^2}$  ohms, where  $X_L = 2\pi\nu L$  ohms (the inductance

$L$  has to be in henrys, not mH, etc.) and  $X_C = \frac{1}{2\pi\nu C}$  ohms (the capacitance

$C$  has to be in farads, not mf or pf, etc.). In this problem there is no capacitance. As such, the

impedance expression becomes  $\sqrt{R_{net}^2 + (2\pi\nu L)^2} = [(1100 \Omega)^2 + [2\pi(20000 \text{ Hz})(10 \times 10^{-3} \text{ H})]^2]^{1/2} = 1670 \Omega$ . (Note that if you made the mistake of using 2000 hertz in the calculation instead of 20,000 hertz, you got this incorrect response. It is interesting to note, though, how much the answer can differ when the frequency varies by as little as a factor of 10). This response is false.]

b.)  $1255 \Omega$ . [Nope.]

c.)  $1670 \Omega$ . [This is the one.]

d.) None of the above. [Nope.]

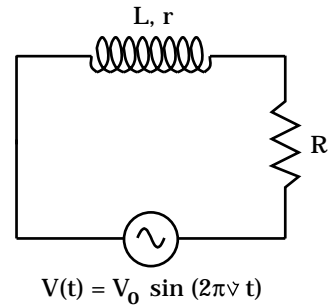

20.) Three current-carrying wires oriented perpendicular to the page are positioned at the corners of a triangle as shown. Assuming the current magnitudes are the same for all of the wires, the net magnetic field at the center of the triangle will be as shown if:

a.) Currents C and D are both out of the page. [All you can do with a question like this is diddle around with various combinations, graphically adding the resulting magnetic fields for different combinations. In fact, the second sketch shows the correct combination. This response is false.]

b.) Currents C and D are both into the page. [Nope.]

c.) Current C is into the page and current D is out of the page. [This is the one.]

d.) None of the above. [Nope.]

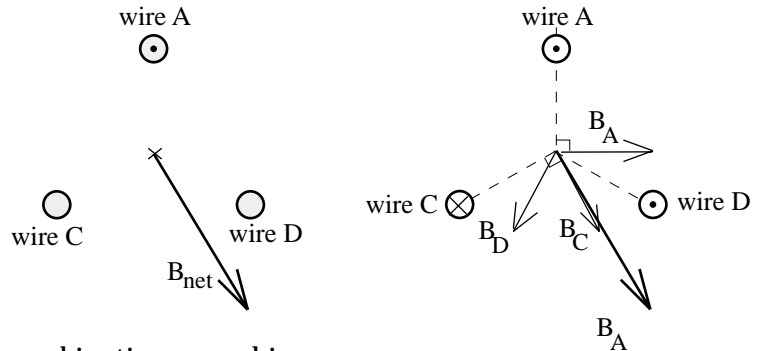

21.) A hollow sphere of inside radius  $a$  and outside radius  $2a$  has a volume charge density shot through it of  $k_2/r$ , where  $k_2$  is a constant. The electric field function for the region between  $a$  and  $2a$  is:

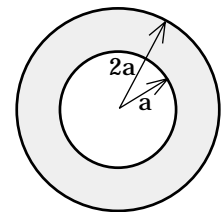

- a.)  $\frac{k_2}{2\epsilon_0}$ , and that function would have been different if the outside radius had been  $3a$ .

[To begin with, we must determine the amount of charge that exists inside a Gaussian sphere whose radius  $r$  is between  $a$  and  $2a$ . Because the charge distribution is not constant, we must define a differential volume  $dV$  of radius, say,  $c$ , that has a differential thickness of  $dc$ . The expression for  $dV$  can be determined by noticing that the surface area of a sphere whose radius is  $c$  will be  $4\pi c^2$ , and that multiplying that quantity by the differential thickness  $dc$  yields the differential volume  $dV = (4\pi c^2)dc$ . Multiply that expression by the volume charge density function ( $k/r$  in this case), evaluate it at  $c$ , and we have all we need to do the Gaussian integral. Jumping almost immediately to the standard form for the left side of Gauss's Law, given that we are working with spherical symmetry, we can write:

$$\begin{aligned} \int \mathbf{E} \cdot d\mathbf{S} &= \frac{q_{\text{enclosed}}}{\epsilon_0} \\ \Rightarrow E(4\pi r^2) &= \frac{\int_{c=a}^r \rho dV}{\epsilon_0} \\ \Rightarrow E &= \frac{\int_{c=a}^r (k_2/c)(4\pi c^2 dc)}{(4\pi r^2)\epsilon_0} \\ \Rightarrow E &= \frac{k_2 \int_{c=a}^r (c) dc}{r^2 \epsilon_0} \\ \Rightarrow E &= \frac{k_2 \left[ \frac{c^2}{2} \right]_a^r}{\epsilon_0 r^2} \\ \Rightarrow E &= \frac{k_2}{2\epsilon_0 r^2} (r^2 - a^2). \end{aligned}$$

The response quoted in this selection seems to be the correct integral evaluated at  $a = 0$ , which makes no sense as the derived function is good only for the region  $r$  between  $a$  and  $2a$ . As such, this response is false.]

- b.)  $\left( \frac{k_2}{2\epsilon_0 r^2} \right) (r^2 - a^2)$ , and that function would have been different if the outside radius had

been  $3a$ . [It turns out that this is the correct electric field function, as derived above, but the function wouldn't have been different if the sphere's outside radius had been  $3a$ . Why? Notice that our derivation never took into consideration the outside radius of the sphere. The Gaussian approach we have been using is interested only in the charge enclosed inside the Gaussian surface--a surface whose radius is less than the outer radius of the sphere. This response is false.]

- c.)  $\frac{k_2}{2\epsilon_0}$ , and that function would not have been different if the outside radius had been  $3a$ .

[Nope.]

- d.)  $\left(\frac{\mathbf{k}_z}{2\epsilon_0 r^2}\right)(\mathbf{r}^2 - \mathbf{a}^2)$ , and that function would not have been different if the outside radius had been  $3a$ . [This is the one.]
- e.) None of the above. [Nope.]

22.) When the switch is closed:

a.) The power dissipated by  $R$  increases. [When the switch is thrown, one battery is shorted out. The voltage across  $R$  before the switch is closed is 20 volts. After the switch is closed, the voltage across  $R$  is 10 volts. As the resistance doesn't change but the voltage goes down, the current through  $R$  will decrease as will the power dissipated by  $R$  (this additionally means that the power supplied to the circuit by the battery complex will also go down). This response is false.]

b.) The power drawn from the power supply complex increases. [From above, this is false.]

c.) The current in the circuit increases. [From above, this is false.]

d.) The equivalent resistance of the circuit increases. [This is interesting. When a resistor in a parallel combination is removed, the amount of current drawn from the power supply decreases and the equivalent resistance of the parallel combination goes up. In this case, the current is, indeed, going down, but it isn't because the equivalent resistance has changed--it is because the voltage has changed. This response is false.]

e.) None of the above. [This is the one.]

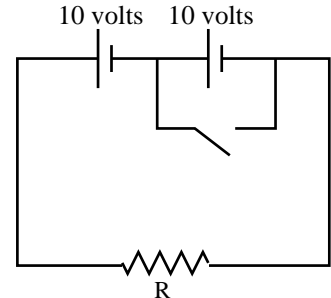

23.) Charges are placed as shown at the corners of a rectangle.

a.) Along the line between  $Q$  and  $2Q$ , the x-component of the net electric field setup by the four charges will be toward the right side of the page, and the y-component will be toward the top of the page. [In the section between  $Q$  and  $2Q$ , the x-component of the electric field will be due to the  $3Q$  and  $4Q$  charges. Being positive, they will produce an electric field whose x-component will be directed toward the left. This response is false.]

b.) Along the line between  $Q$  and  $2Q$ , the x-component of the net electric field setup by the four charges will be toward the left side of the page, and the y-component will be toward the top of the page. [The first part is true. As for the second part, the  $2Q$  charge will overpower the  $Q$  charge, and the net field due to those two will be in the upward direction as long as you don't get too close to  $Q$ . When you get close to  $Q$ , that smaller but closer charge predominates and the field direction is downward. As for the other two charges, their net effect in the y-direction will be upward as the  $4Q$  charge will predominate over the  $3Q$  charge. In any case, this response is false because at least at some point very near  $Q$ , the direction of the field will be downward.]

c.) Along the line between  $Q$  and  $2Q$ , the x-component of the net electric field setup by the four charges will be toward the right side of the page, and the y-component will be toward the bottom of the page. [Nope.]

d.) Along the line between  $Q$  and  $2Q$ , the x-component of the net electric field setup by the four charges will be toward the left side of the page, and the y-component will be toward the bottom of the page. [Nope.]

e.) None of the above. [Because none of the responses maintain that the y-component along the line between  $Q$  and  $2Q$  will be up or down, depending upon how close you are to  $Q$ , none of the above are true and this is the correct response.]

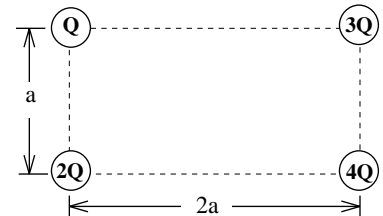

- 24.) For a given primary voltage, doubling the winds in the secondary of a transformer will:
- Double both the secondary voltage and the secondary current. [You don't get something for nothing. Translation: you can't increase both the voltage AND the current in the secondary coil. Doing so violates the conservation of energy. This response is false.]
  - Halve the secondary voltage and double the secondary current. [The relationship between the voltage ratio and the winds ratio is  $V_p/V_s = N_p/N_s$ . Doubling  $N_s$  doubles  $V_s$ . This response is false.]
  - Double the secondary voltage and halve the secondary current. [From above, the first part of this is true. As for the second part, the inverse relationship between secondary voltage and secondary current maintains that if the voltage doubles, the current must halve. This response is true.]
  - None of the above. [Nope.]

25.) The constant electric field shown in the sketch has a magnitude of 100 volts/meter. The voltage at B is 200 volts. The voltage at A is:

- 100 volts. [If we move from B to A, the voltage difference  $V_B - V_A$  will equal  $-Ed \cos \phi$ , where E is the magnitude of the electric field vector, d is the magnitude of the distance between A and B, and  $\phi$  is the angle between the line of E and the line of d (if we are moving from B to A, d will be drawn from B to A--where you start and where you end is important as it affects not only the angle  $\phi$  but also which voltage goes where on the left side of the equation). Presented algebraically, then with numbers (noting that  $\cos 120^\circ = -.5$ ), this is:

$$\begin{aligned}
 V_A - V_B &= -Ed \cos \phi \\
 \Rightarrow V_A - (200 \text{ volts}) &= -(100 \text{ volts / meter})(6 \text{ meters}) \cos 120^\circ \\
 \Rightarrow V_A &= 500 \text{ volts.}
 \end{aligned}$$

This makes sense--A is upstream from B. This suggests that A's voltage is larger than B's. In any case, if you managed to mess up the angle, you might have gotten the answer given in this response. It is incorrect and this response is false.]

- +100 volts. [Nope.]
- +500 volts. [This is the one.]
- None of the above. [Nope.]

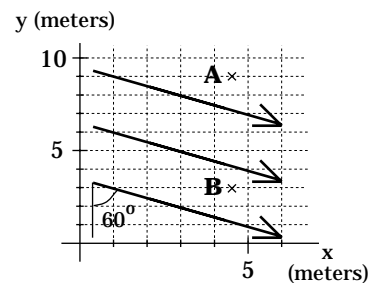

26.) The capacitors in the circuit shown are initially uncharged. If the switch is closed at  $t = 0$ , what is the maximum charge the  $12 \mu\text{f}$  capacitor will hold?

- $2 \times 10^{-4}$  coulombs. [As the capacitors are in series, the charge on each at a given instant will be the same. At full charge, there will be no current in the circuit and we can assume that each capacitor's charge is Q. Additionally, the sum of the voltage drops across the two capacitors will equal the voltage across

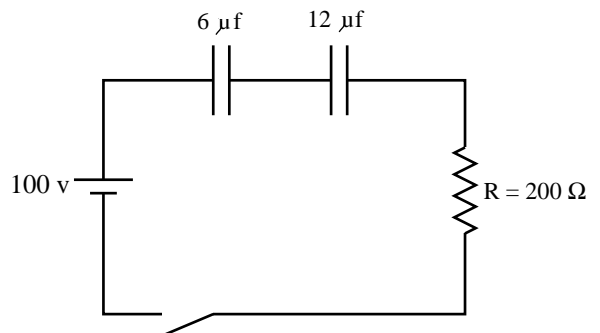

the power supply. That means that  $(100 \text{ volts}) = \frac{Q}{C_1} + \frac{Q}{C_2} = \frac{Q}{(6 \times 10^{-6} \text{ farads})} + \frac{Q}{(12 \times 10^{-6} \text{ farads})}$ ,

or  $Q = 4 \times 10^{-4}$  coulombs. NOTE: This value could have been determined by calculating the equivalent capacitance and using  $V = Q/C_{\text{eq}}$  to determine  $Q$ . This response is false.]

- b.)  $4 \times 10^{-4}$  coulombs. [This is the one.]
- c.)  $6 \times 10^{-4}$  coulombs. [Nope.]
- d.) None of the above. [Nope.]

27.) An aluminum ramp tilted at an angle  $\theta$  is connected to a large voltage source as shown in the sketch. The assembly is bathed in a large B-field (for the field's orientation, see the sketch). A very light aluminum cylinder is placed across the ramp and released. Assuming the battery's voltage is large, but not so large that the current generated in the aluminum cylinder spot-welds the cylinder to the ramp:

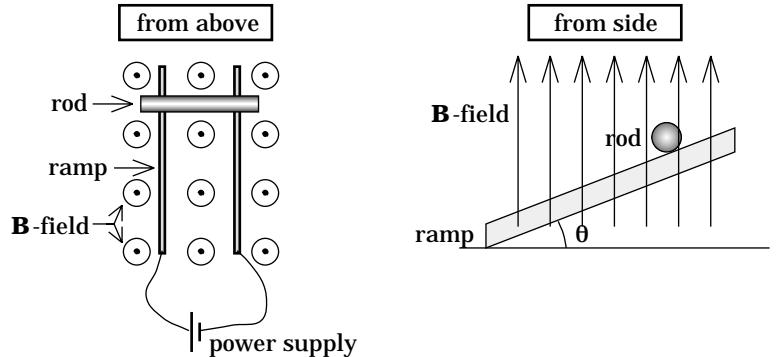

- a.) The cylinder will roll down the incline but will do so more slowly than if the B-field was not present. [This is a tricky question. It hinges on the way the battery terminals are hooked up and, as a consequence, the direction of current flow through the aluminum cylinder. If the current had passed from right to left in the "from above" view, the magnetic force ( $iL \times B$ ) would have been in the horizontal and to the right as seen in the "from side" view. At the very least, this would have retarded the motion (in fact, an adjustment to the voltage could have brought the cylinder to a full stop or even completely overcome the component of gravity down the ramp making the cylinder accelerate up the incline). As the circuit stands, though, the battery connection makes current flow from the left to the right. This produces a magnetic force on the rod that is horizontal and to the left as seen in the "from above" view. A force in that direction aids gravity in accelerating the rod down the incline. In short, this response is false.]
- b.) The cylinder will roll down the incline but will do so faster than if the B-field was not present. [This is the one.]
- c.) The cylinder will roll down the incline as though there was no B-field present because aluminum is not a magnetic substance and, hence, will not be affected by the B-field. [Just because aluminum isn't a ferromagnetic material and can't be magnetized doesn't mean it can't have current flow through it which will interact with an external magnetic field. This response is false.]
- d.) The cylinder will roll up the incline. [This could have been the correct answer if the battery terminals had been reversed and the battery voltage adjusted accordingly. That wasn't the case, so this response is false.]
- e.) The cylinder will not roll at all but will remain stationary. [This could have been the correct answer if the battery terminals had been reversed and the battery voltage adjusted accordingly. That wasn't the case, so this response is false.]

28.) An electric field along the x-axis is defined by the graph shown. The electrical potential function that goes with this electric field is:

- a.) A constant. [The relationship that allows us to determine  $V(x)$

when we know  $E(x)$  is  $\Delta V = -\int \mathbf{E} \cdot d\mathbf{r}$ . The cheap way to do this is to simply

determine a function for  $E$ , then do the integral. Because people are often more comfortable with math than conceptualizing, let's do it that way first. By inspection, the electric field is a linear function equal to  $kr$ , where  $k$  is a constant (in this case 10) that scales the numerical value of the position to fit the numerical value for the electric field at that position (note that at  $r = .2$  meters, the electric field  $E = 2$  newtons--the scaling factor is 10

nt/m). Taking the integral  $\Delta V = -\int \mathbf{E} \cdot d\mathbf{r}$  between the electric field's zero point ( $r = 0$  in this

case) and an arbitrary position  $r$ , we get  $kr^2/2$ , a decidedly quadratic beast. In short, this response is false. PROBABLY MORE IMPORTANT THAN THE ANSWER, though, is understanding from an intuitive perspective what is going on. The relationship  $\Delta V = -\int \mathbf{E} \cdot d\mathbf{r}$  is the

integral form of the differential relationship  $dV = E dr$ . This relationship essentially says the following: Take  $E$  at a point and multiply it by a tiny displacement  $dr$  about that point. The resulting number yields the work per unit charge available to be done if a charge was to move through the displacement  $dr$ . Additionally, according to the relationship, this number is also equal to minus the voltage change over  $dr$ . Putting the integral into the relationship essentially says to do this  $E dr$  operation for all of the differential displacements between your two points of interest, then sum the outcome of all of those dot products. That sum will give you minus the net electrical potential difference (the net voltage difference) between those two points. In general, what we ultimately are looking for is the function that describes the voltage at particular points, relative to a zero point. That voltage will be the area under the electric field versus position graph, evaluated between the zero point and the point of interest. If that area increases linearly (this would correspond to a constant electric field), the voltage is a linear function. If that area increases quadratically (this corresponds to a linear electric field), the voltage function is a quadratic. In our case, the electric field is linear and the voltage function is quadratic. This response is false.]

- b.) Linear along the x-axis. [Nope.]  
 c.) Quadratic along the x-axis. [This is the one.]  
 d.) None of the above. [Nope.]

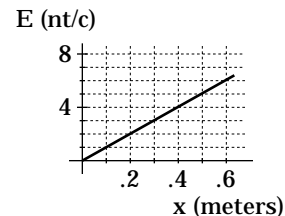

29.) In the circuit shown, what will the ammeter read?

a.) 2 amps. [This value was determined by simply summing up all the resistance values and dividing them into the battery voltage. This is not a kosher move. There are two ways to do this. You can either look at the sketch as it stands and try to make sense of it in that form, or you can re-work the diagram to get it into a more visually edifying form (the sketch to the right does just that). If you try to use the original sketch, the important point to note is that the voltage drop between A and B will be the same as the voltage drop between A and C (in both cases, there is only one  $1 \Omega$

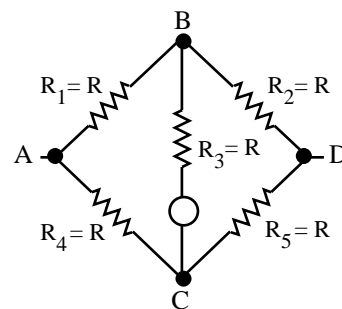
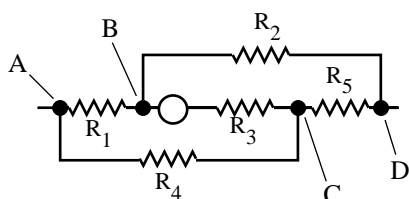
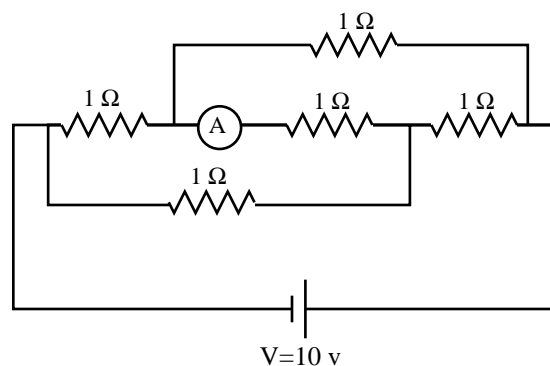

resistor between A and the point of interest). That means that the voltages at B and C will be equal. With no voltage difference between those points, there will be no current through that branch and this response is false. NOTE: If you re-sketch the circuit into the form shown, the observations made above are even easier to see.]

- b.) 1 amp. [Nope.]
- c.) Zero amps. [This is the one.]
- d.) None of the above. [Nope.]

30.) Two charges  $q_a$  and  $q_b$  repulse one another with force  $F$ . If  $q_a$ 's charge doubles while the distance between the two charges halves, the new force will be:

a.)  $F/4$ . [Coulomb's law states that the force on one point charge due to the presence of a second point charge will be  $\frac{1}{4\pi\epsilon_0} \frac{q_1 q_2}{r^2}$ , where the  $q$  terms are the charges in question and the  $r$  term is the distance between the charges. If the sole change in the system had been the diminishing of  $r$  by a factor of two (i.e., a halving of the distance), the force would have gone up by a factor of  $1/r^2 = 1/(1/2)^2$ , or 4. If the sole change in the system had been the doubling of one of the charges, the force would have double. With both the doubling of a charge and the halving of the distance, the force has to go up by a factor of 8. This response is false.]

- b.)  $F/2$ . [From above, this is not the one.]
- c.)  $2F$ . [From above, this is not the one.]
- d.)  $4F$ . [From above, this is not the one.]
- e.)  $8F$ . [From above, this is the one.]

31.) A uniformly charged sphere of radius  $a$  has a Gaussian surface (a sphere) placed about it. The radius of the Gaussian surface is  $a$  (that is, the Gaussian surface is placed directly on top of the sphere's outer edge). For that situation, the net flux through the Gaussian surface is  $\phi$ . The radius of the Gaussian sphere is then halved to  $r/2$  with everything else held constant. For this new situation, the net flux through the surface will be:

a.)  $\phi/2$ . [The volume of a sphere is  $4\pi r^3/3$ . Halving the radius changes the volume by a factor of  $(1/2)^3 = 1/8$ . If the charge is uniformly distributed, a volume that is  $1/8$  of the whole will produce a Gaussian surface with  $1/8$  of the total charge in it. This, in turn, will produce an electric flux of  $(Q/\epsilon_0)/8$ . This corresponds to an electric flux that is  $1/8$  the original flux, and this response is false.]

- b.)  $\phi/4$ . [Nope.]
- c.)  $\phi/8$ . [This is the one.]
- d.) None of the above. [Nope.]

32.) A wire with current directed as shown feels a magnetic force in which direction?

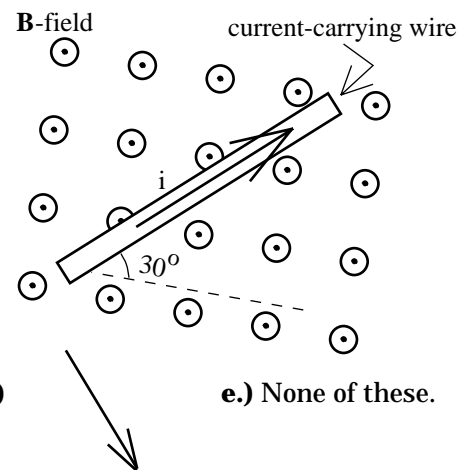

- a.) 
- b.) 
- c.) 
- d.) 
- e.) None of these.

[Commentary: Using  $F = iL \times B$ , the force direction determined by the right-hand rule matches the direction presented in Response d.]

33.) If the frequency is doubled in this circuit:

a.) The resistive nature of the capacitor will double and the current will halve. [The resistive nature of a capacitor is its capacitive reactance.

That quantity is mathematically equal to  $\frac{1}{2\pi\nu C}$ . Doubling the frequency will halve the capacitive reactance which, in turn, means the resistive nature of the capacitor halves. Going no farther, this response is false.]

b.) The resistive nature of the capacitor will halve and the current will double. [From above, the first part of this response is true. As for the second part, this is a bit tricky. The current in the circuit is governed by Ohm's Law. That is,  $V_{RMS} = i_{RMS} Z$ , where  $Z$  is the circuit's impedance at the frequency of operation. We have already established that the capacitive reactance halves with a doubling of the frequency, but how does the circuit's net resistive nature--its impedance--change? The

impedance expression for an RC circuit is  $\sqrt{R_{net}^2 + \left(\frac{1}{2\pi\nu C}\right)^2}$ . Because it is governed not only by the frequency-dependent capacitive reactance but also by the net resistance in the circuit, the impedance will diminish when the frequency is doubled, but not by a half. As the impedance change is not half, the current will not double and this response is false.]

c.) The resistive nature of the capacitor will double and the current will double. [If nothing else, you wouldn't expect the resistive nature to go up and additionally have the current go up. The two are at opposite ends of the pole--big current means small resistance, and vice versa. This response is false.]

d.) The resistive nature of the capacitor will halve and the current will halve. [Nope.]

e.) None of the above. [This is the one.]

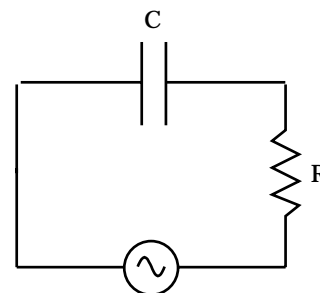

$$V(t) = V_0 \sin(2\pi\nu t)$$

34.) Two charges are placed along the x-axis as shown. A graph of the electric field  $E$  versus position  $x$  between the charges looks like:

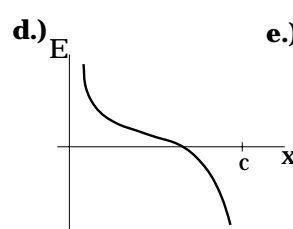
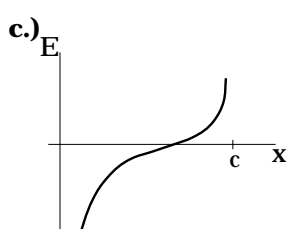
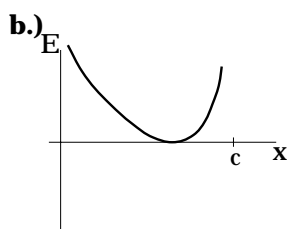
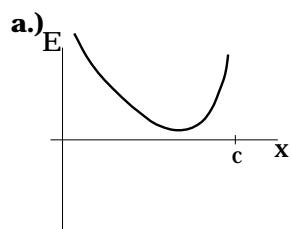
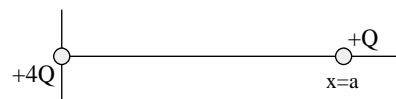

e.) None of these.

[Commentary: As the charges are like, there will be a place between them where the net electric field is zero (this eliminates Response a). As the charge at the origin is much larger than the charge out along the axis, the place where the electric field will be zero will be beyond the halfway point between the charges (this eliminates Response a). The field close to the origin will be directed in the  $+x$  direction, which means that its field value must be positive (this eliminates Response c). Close to the second charge, the direction of the net electric field will be in the  $-x$  direction (this eliminates Response b). Response d resembles a combination of  $1/r^2$  functions. This is the one.]

35.) In the system shown, the switch has been set on contact A for a long time. At  $t = 0$ , the switch flips from contact A to contact B. The current in the circuit just after  $t = 0$  will be:

a.) .02 amps. [Because the capacitor has been in series with the battery for a long period of time, the voltage across the  $5\ \Omega$  resistor will be zero (i.e., there will be no current in the circuit at that time) and the voltage across the capacitor will be 400 volts. When the switch flips, the situation we find is a 400 volt potential drop across the capacitor in parallel with a  $200\ \Omega$  resistor. The 400 volts across the resistor will produce a current  $i = V/R = (400\ \text{v})/(200\ \Omega) = 2$  amps. This response is false.]

- b.) 1 amp. [Nope.]  
 c.) 2 amps. [This is the one.]  
 d.) None of the above. [Nope.]

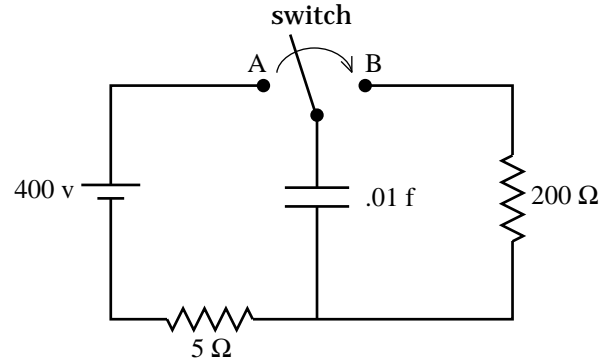

36.) A 50 turn coil of radius  $r = .2$  meters and resistance  $R = 12\ \Omega$  faces a uniform B-field coming out of the page that doubles at a constant rate every 10 seconds. At  $t = 0$ , the magnetic field intensity is .25 teslas. The magnitude of the electric field setup in the coil will be:

a.) .1 newton/coulomb. [The relationship between the induced electric field and the induced EMF in a circuit like this is  $N \frac{d\Phi_m}{dt} = -\oint \mathbf{E} \cdot d\mathbf{l}$ , where  $dl$  is a differential length of a section of the coil and  $\mathbf{E}$  is the induced electric field vector in the wire (this should be in the direction of  $d\mathbf{l}$ ). Doing the problem yields:

$$\begin{aligned} N \frac{\Delta\Phi_m}{\Delta t} &= -\oint \mathbf{E} \cdot d\mathbf{l} \\ \Rightarrow N \frac{\Delta(BA \cos 0^\circ)}{\Delta t} &= -\oint (E)(dl) \cos 0^\circ \\ \Rightarrow N \left( \frac{\Delta B}{\Delta t} \right) A &= -E \oint (dl) \\ \Rightarrow (50) \frac{[(.5 \text{ teslas}) - (.25 \text{ teslas})]}{10 \text{ seconds}} [\pi(.2 \text{ meters})^2] &= -E(2\pi(.2 \text{ meters})) \\ \Rightarrow E &= -.125 \text{ newtons / coulomb.} \end{aligned}$$

What does the negative sign mean? Technically,  $d\mathbf{l}$  should be oriented so that if the thumb of the right hand is positioned along the line of the external magnetic field, the fingers of the right hand curl in the general direction of  $d\mathbf{l}$ 's circulation around the coil. In this case, that direction is counterclockwise. In doing the dot product in the electric field integral, we assumed that the directions of  $\mathbf{E}$  and  $d\mathbf{l}$  were the same. They apparently weren't, hence the negative sign in front of the calculated value of  $E$  (i.e., this suggests that the electric field circulates clockwise). Note that the direction of the induced current and the direction of the induced B-field will be opposite the direction of the external B-field. The induced current required to produce such an induced B-field is in the clockwise direction, just as suspected. In any case, this response is false.]

- b.) .125 newtons/coulomb. [This is the one.]

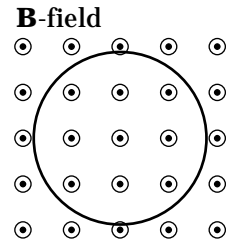

- c.) .15 newtons/coulomb. [Nope.]  
 d.) None of the above. [Nope.]

37.) The voltage across the  $2\ \Omega$  resistor is:

a.) 12.5 volts. [This is so easy it is almost tricky. The temptation is to think that you need to determine the current through the  $2\ \Omega$  resistor so that you can use  $V = iR$  to determine the  $2\ \Omega$ 's voltage. This will work, but there is an easier way. The voltage across the  $2\ \Omega$  resistor is the same as the voltage across the  $1\ \Omega$  resistor, or  $(5\ \text{amps})(1\ \Omega) = (5\ \text{volts})$ . NOTE: This was a deceptive problem if you weren't using your head. Just because there is a standard way of doing something doesn't mean that that approach is always the fastest way to do the calculation. Be creative!]

- b.) 7.5 volts. [Nope.]  
 c.) 5 volts. [This is the one.]  
 d.) None of the above. [Nope.]

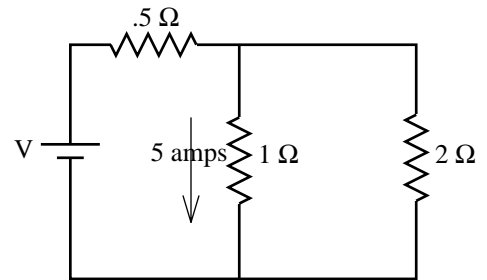

38.) An electrical potential field along the  $x$ -axis is defined by the graph shown. Its associated electric field is:

a.) Always positive and approximately zero at  $x = .45$  meters. [We know that  $E = -\nabla V$ . In one-dimension, this means that the derivative of the electrical potential function (i.e., the function that defines the slope of the tangent of the electrical potential function) is equal to minus the electric field function. In this case, that slope is always positive which means that the electric field will always be negative. What's more, the slope is approximately zero at  $x = 0$  (not  $x = .45$  meters). In fact, there is no significance to  $x = 4.5$  meters except for the fact that for whatever reason, that point has been chosen to be the zero electrical potential point. This response is false.]

b.) Positive up to approximately  $x = .45$  meters and negative after that point. Also, the function will be zero at approximately  $x = .45$  meters. [Nope.]

- c.) Always negative and approximately zero around  $x = 0$ . [This is the one.]  
 d.) None of the above. [Not so.]

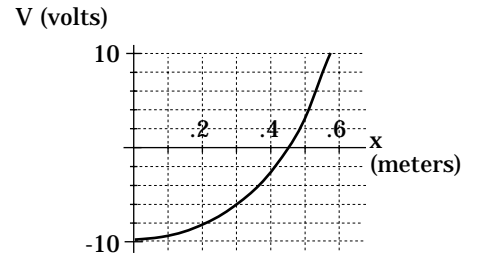

39.) Two wires separated by a distance  $2r$  carry the same current  $i_0$ . The direction of one of the currents is shown in the sketch. The magnetic field halfway between the two wires (call this Point A) is found to be  $B$ , where  $B$  is not equal to zero. If the distance between the wires is changed to  $6r$ :

a.) The direction of the second current is upward and the NEW magnetic field halfway between the wires is  $B/6$ . [Before the change in separation-distance, the magnetic field at Point A is non-zero. Because the currents are the same,  $B$  would have been zero at A if the current in the second wire had been upward (use the right-thumb rule--the known current produces a magnetic field into the page--an upward current in the unknown line would produce an equal magnitude magnetic field out of the page--the two would add to zero . . . an unacceptable outcome). That means the unknown current direction must be downward, and this response is false.]

b.) The direction of the second current is upward and the NEW magnetic field halfway between the wires is  $B/3$ . [Wrong current direction. This response is false.]

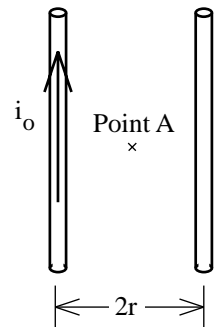

c.) The direction of the second current is downward and the NEW magnetic field halfway between the wires is  $B/6$ . [This response has the correct unknown current direction. Continuing on, B is the net magnetic field due to both wires combined. Nevertheless, determining what happens to just one wire will give us enough information to determine how the net magnetic field will change with the increased separation. The expression for the magnetic field produced by a single current-carrying wire is  $B = \frac{\mu_0 i}{2\pi r}$ , where r is the distance between the wire and the point of interest. In this case, the initial distance between either wire and Point A is r. The new distance is 3r. That means the magnetic field intensity is changed by a factor of 1/3 and the net magnetic field after the separation is B/3. This response is false.]

d.) The direction of the second current is downward and the NEW magnetic field halfway between the wires is B/3. [This is the one.]

40) An uncharged sphere made of a conducting substance is placed between oppositely charged plates (see sketch). The electric field lines between the plates will look like:

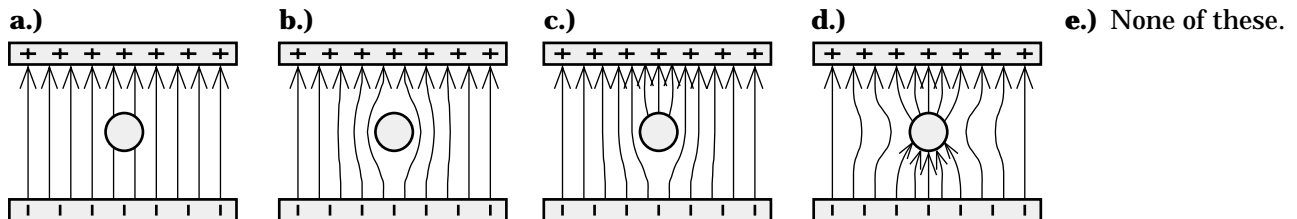

[Commentary: This question appears to be asking what you think happens to a conductor when it is placed in a relatively uniform electric field (e.g., the one produced by the plates). If that had been all there was to it, the answer would have been simple. Electrons in the conducting ball would have migrated making the top side of the ball (i.e., the side closest to the positive plate) electrically negative while leaving the bottom side of the ball electrically positive. This polarization would have altered the general look of the electric field lines from the simple, parallel plate situation (without the ball presence) approximated in Response a to the general look shown in Response d. But Response d is wrong. Why? Electric fields always point from positive charge accumulation to negative charge accumulation. The field lines as depicted are all oriented opposite to that. In short, all of the field lines shown are oriented in the wrong direction. Response e is the correct answer.]

